

A

B

C

D

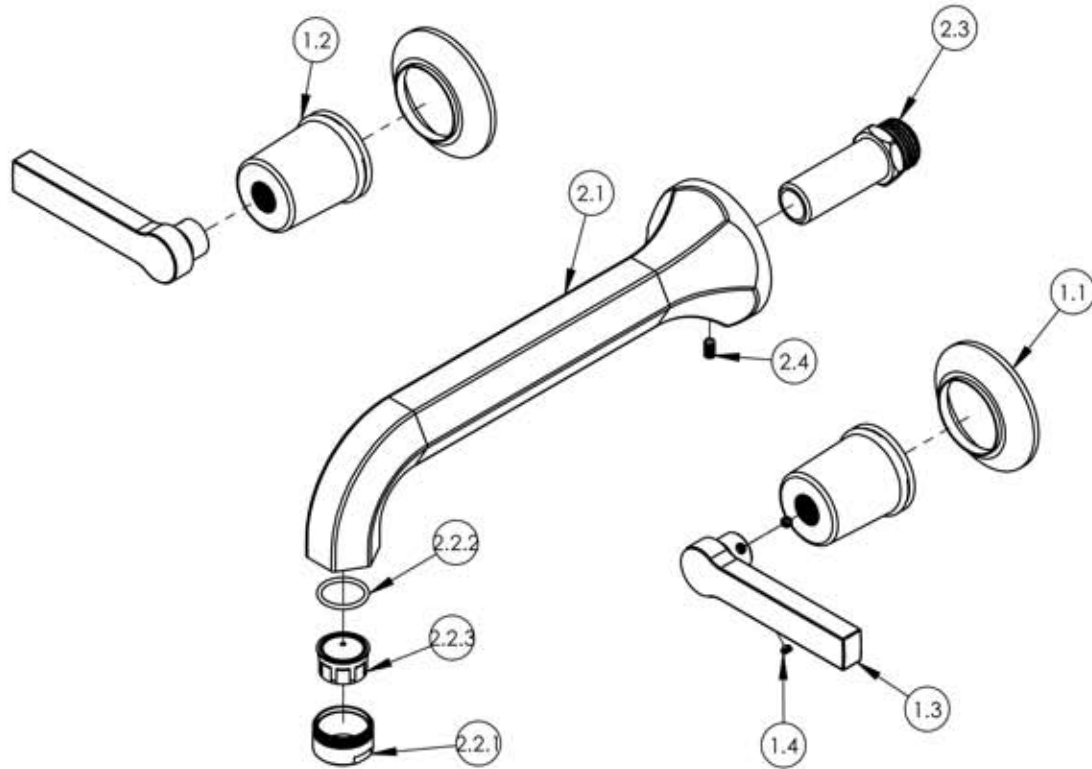

ITEM NO.	PART NUMBER	DESCRIPTION	QTY.
1	3-133/00	LEVER HANDLE, HEX MODERN, 501 SERIES	2
1.1	10921/00	ESCUTCHEON, TRANSITIONAL	1
1.2	10922/00	HUB, FOR HEX TRANSITIONAL	1
1.3	11036/00	HANDLE LEVER, CONTEMPORARY 16PT	1
1.4	92163	SET SCREW, CONE PT 8-32 X 1/8" L	2
2	3-147/00	SPOUT, WALL TUB, 500/501 SERIES	1
2.1	10427/00	SPOUT WALL, HEX	1
2.2	3-409/00	AERATOR, 15/16" MALE HOUSING FULL FLOW	1
2.2.1	10784/00	HOUSING, AERATOR 15/16"-27	10784
2.2.2	90017	O-RING, 11/16" ID X 13/16" OD X 1/16" THK, AS-568-017	1
2.2.3	30031	AERATOR, FULL FLOW 15/16"-27	1
2.3	10432	NIPPLE, WALL SPOUT	1
2.4	92010	SET SCREW, CUP POINT 8-32UNC 5/16" LENGTH SS	1

E

ZONE	REV.	DESCRIPTION	DATE	APPROVED
------	------	-------------	------	----------

REVISIONS

1261 LOGAN AVENUE
COSTA MESA, CALIFORNIA 92626
PHONE: 714.361.4800
FAX: 714.617.3120

PHYLTRICH®

Defining Luxury Since 1959

PROPRIETARY AND CONFIDENTIAL

THE INFORMATION CONTAINED IN THIS DRAWING IS THE SOLE PROPERTY OF RISS MANUFACTURING. ANY REPRODUCTION IN PART OR AS A WHOLE WITHOUT THE WRITTEN PERMISSION OF RISS MANUFACTURING IS PROHIBITED.

-	-	INTERPRET GEOMETRIC DIMENSIONING & TOLERANCING IN ACCORDANCE WITH ASME Y14.5-2009 & ASME Y14.41-2003 STANDARDS, UNLESS OTHERWISE SPECIFIED. DIMENSIONS ARE IN INCHES. TOLERANCES ARE:		
NEXT ASSY	USED ON	FRACTIONS ±1/64"	DECIMALS X.X: ±.1 X.XX: ±.01 X.XXX: ±.005	ANGULAR ±5°
APPLICATION		MATERIAL	NAME	DATE
FINISH		DRAWN	FME	11/20/2015
DO NOT SCALE DRAWING		CHECKED	LLO	

WALL MOUNT TUB SET, LEVER HANDLES,
HEX MODERN SERIES

SIZE	ASM/PRT NO.	REV
A	501-57/00	-

SCALE: 1:3 WEIGHT: lbs. SHEET 1 OF 2

5

4

3

2

1